

**Introduction**

The Phenix fibersect.multi.2 and fibersect.single both cut the epoxy and fiber protruding from the face of the ferrule during connector installation. Suitable adapters are available for fully assembled connectors and bare ferrules. Connector and ferrule adapter adjustments are discussed below.









**Cut Distance Adjustment**

The cut distance from the face of the ferrule is adjusted by rotating the Adjusting Ring. A tool is provided that engages the two holes in the ring to facilitate rotation. Adapters are shipped with the cut distance adjusted to ~200 μm. Rotate the Adjusting Ring clockwise to cut closer to the face of the ferrule; rotate counterclockwise to cut further away. Marks along the adapter ring perimeter represent increments of 25 μm. Any distance from 0 to 600 μm can be set. Always adjust the cut distance in small steps and under controlled conditions to minimize the chance of cutting into the ferrule. The saw will not be significantly damaged if the ferrule is accidentally cut, but will wear prematurely if done repeatedly. If the ferrule is cut, immediately adjust the adapter to increase cut length to avoid continued saw wear.

**Adapter Orientation Adjustment**

After adjusting for cut distance, adjust the rotational orientation of the adapter, as required and described below.

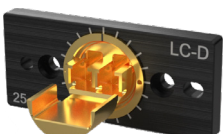
**Orientation Required**

		MT MT-APC Q-MTitan	Use the included Orientation Adjust tool to ensure that the ferrule slot is horizontal with the engraved arrow pointed down. Ferrule should be inserted with the epoxy fill window pointed down.
		TMT-APC	Use the extension to rotate the adapter so that the ferrule slot is horizontal with the extension below the hole. Ferrule should be inserted with the two chamfered edges up, as shown on the Adapter Plate.
		LC-APC SC-APC LC-D CS	Rotate the adapter until the its extension is down, as shown.
			
		FC-APC	Insert a connector and use it to rotate the adapter until the key slot is up.



MDC  
MDC-J  
SN

Rotate the adapter until the its extension is down, as shown.



**Orientation Recommended**



LC  
SC

Rotate the adapter until the its extension is down, as shown. The cut will be parallel to the ferrule face in any orientation, but this will make it more convenient to insert.

**Orientation Not Necessary**

All adapters shown here do not require any adjustment and will cut parallel to the face of the ferrule in any orientation.



LC Ferrule  
SC Ferrule



ST Connector  
FC Connector



P29504-4  
S29504-5



M29504-14/15  
M29504-16



SMA  
ELIO



ARINC 801  
LD-80

**Other Recommendations**

Before inserting the connector or ferrule, ensure that bare fiber protruding from the face of the ferrule is no more than 7 mm. A longer length will result in broken fibers. A length of 7 mm or less is recommended to minimize breakage during handling. For best results, ensure that the bare fiber is completely surrounded and supported by epoxy where the cut occurs. Because of the smaller bead of epoxy used for single fibers, a cut close to the ferrule face may be necessary (20 µm to 80 µm).